

Innovative & Flexible Milling & Cutting Solutions

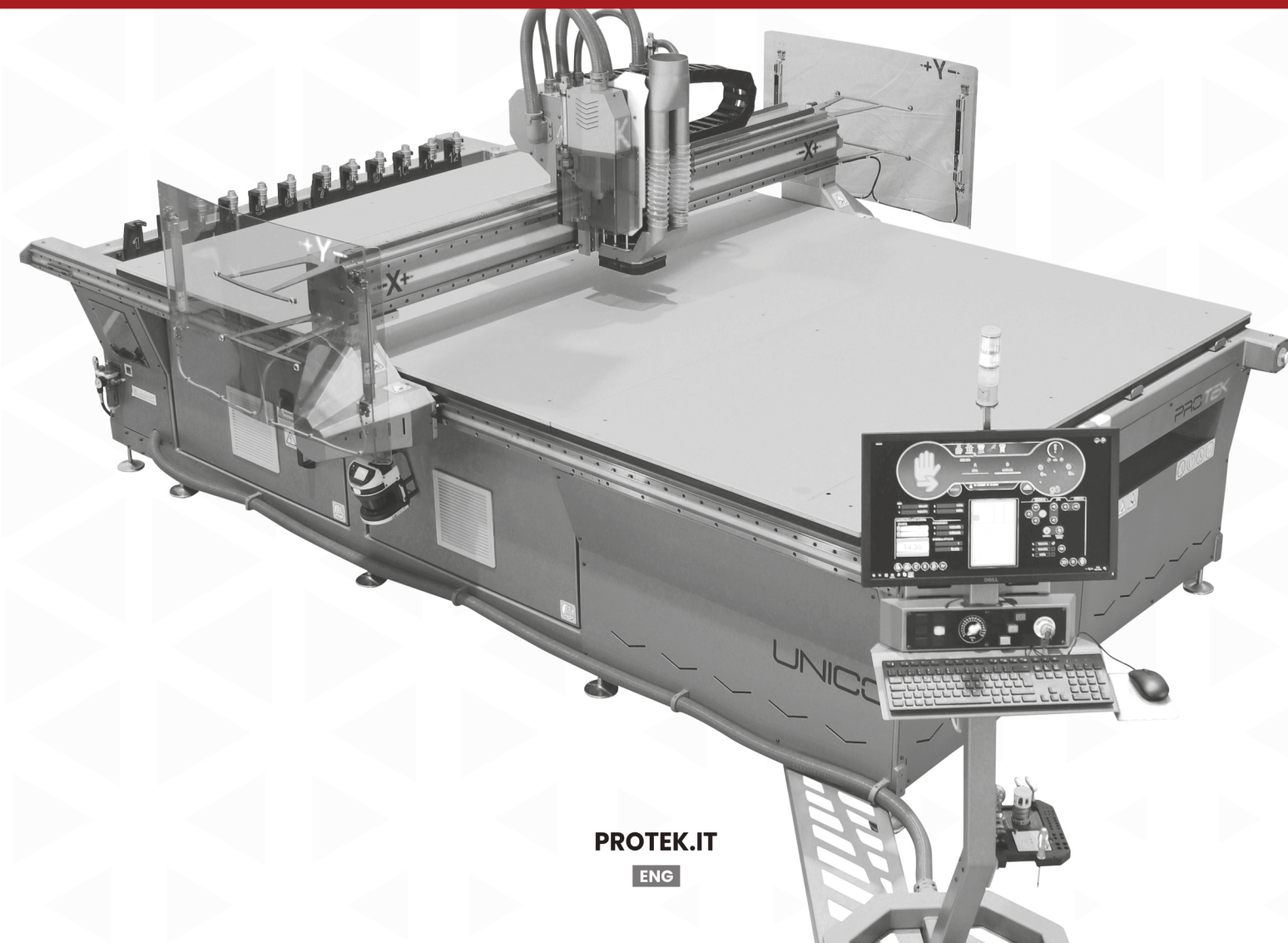

UNICO CNC

THE SMART MILLING SOLUTION

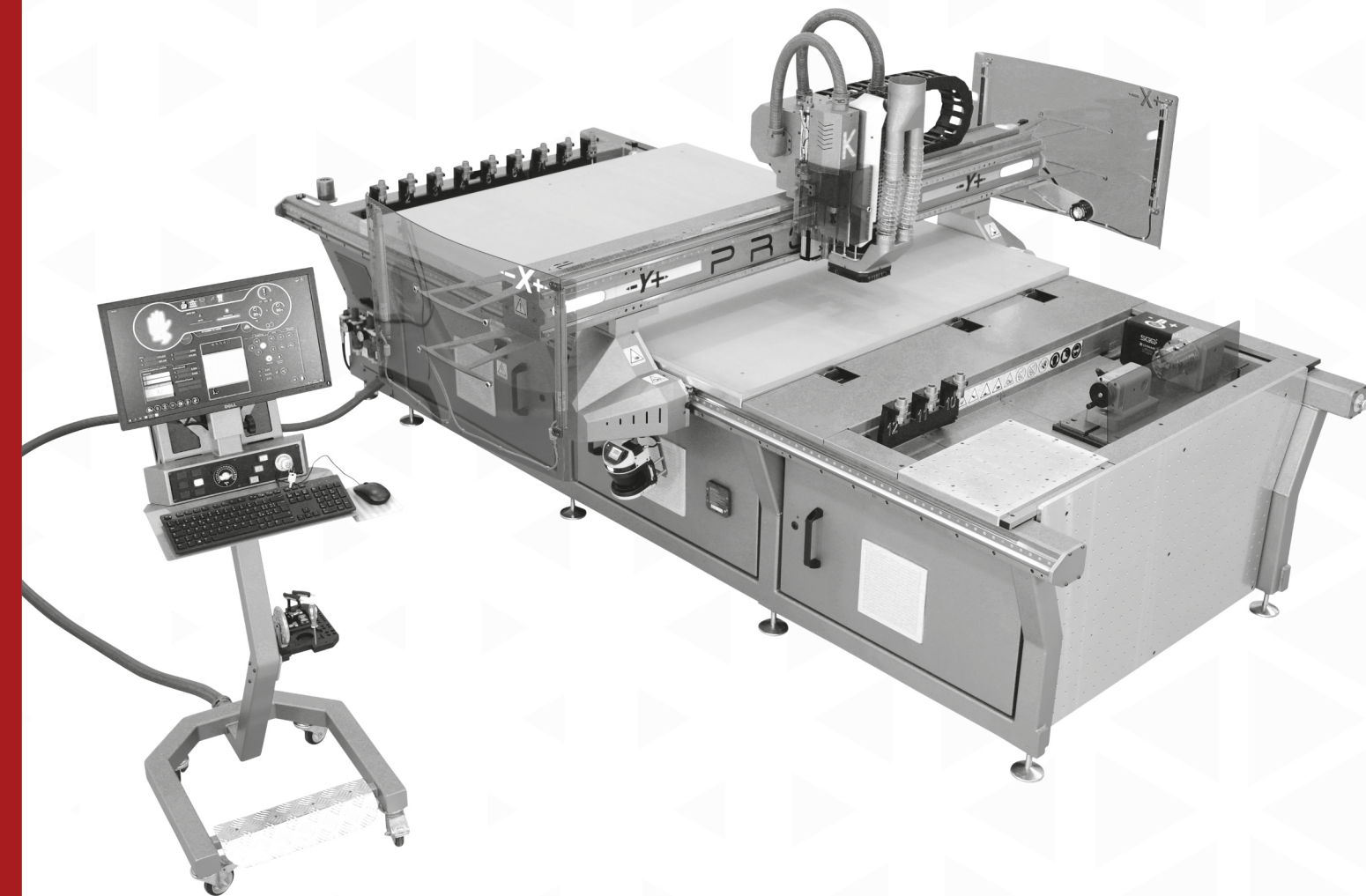

SALES OFFICE

+39 085 8208888
proteksales@protek.it

PROTEK SRL

Via dell'Artigianato 4, 65010
Collecervino, Pescara (PE), Italia (IT)

PROTEK.IT

PROTEK.IT
ENG

UNICO CNC

A smart milling machine for rigid materials, highly customizable.



Machine that ensures you quality and unique finishes, an excellent investment by comparing performance and cost for the customer.

Easy tool path generation and advanced CAD/CAM software.

Electrospindle: 3,6 kW - 50,000rpm / 9 kW - 36,000rpm

Precision: ± 0.04

Control: Mitsubishi CNC

Blocking System with automatic partition with vacuum technology

Tool Changer: Automatic up to 12 positions

Lubrication: Minimum external or internal tool system with programmable intermittence

Width: Up to 2,000 mm

Length: Up to 6,000 mm

Applications: Packaging | Digital Printing | Fashion Accessories | Signs | Industrial Supplies | Facade Cladding | Furnishing | Plastic | Lightweight mechanics



UNICO CNC K

The smart multifunction machine, equipped with a milling unit and customizable cutting unit.

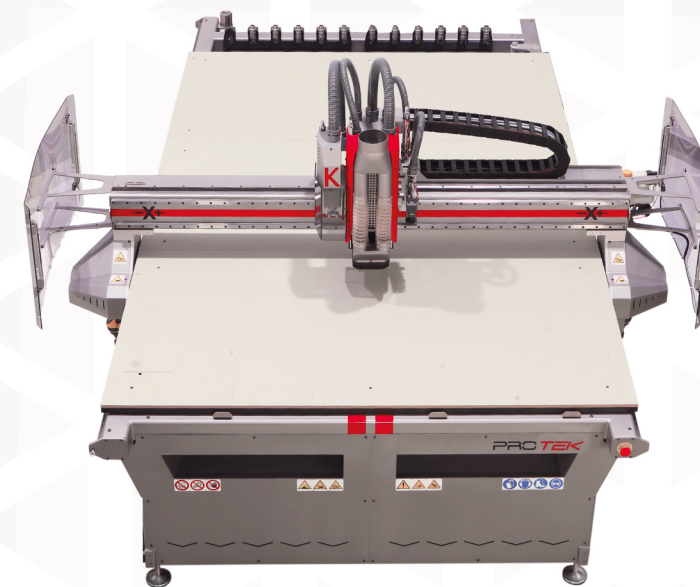

Available with: Oscillating Pneumatic Knife | Oscillating electric Knife | Drag Knife | Kiss Cutting | V-Cut.

Easy tool path generation and advanced CAD/CAM software.

Electrospindle: 3,6 kW - 50,000rpm / 9 kW - 36,000rpm

Precision: ± 0.04

Control: Mitsubishi CNC

Blocking System with automatic partition with vacuum technology

Tool Changer: Automatic up to 12 positions

Lubrication: Minimum external and internal tool system with programmable intermittence

Width: Up to 2,000 mm

Length: Up to 6,000 mm

Applications: Packaging | Digital Printing | Fashion Accessories | Signs | Industrial Supplies | Facade Cladding | Furnishing | Plastic | Lightweight mechanics

